

FEATURES

- ✧ Compatible with GPON & XGPON system. Work in GPON & XGPON system simultaneously.
- ✧ XGPON: Single fiber bi-directional data links TX 9.95Gbps, RX 2.488Gbps application. GPON: Single fiber bi-directional data links asymmetric TX 2488Mbps/RX1244Mbps application
- ✧ 0 to 70°C operating case temperature
- ✧ 3.3V power supply
- ✧ SFP+ package with SC Receptacle connector
- ✧ Hot-pluggable capability
- ✧ XGPON: High power 1577nm EML LD & High sensitivity 1270nm APD. GPON: 1490nm DFB LD & High sensitivity 1310nm APD
- ✧ Support 20km transmission distance with SMF
- ✧ SD indication for GPON&XGPON
- ✧ Low EMI and excellent ESD protection
- ✧ Digital diagnostic monitor interface
- ✧ RoHS6 compliance

APPLICATIONS

- ✧ GPON OLT CLASS C+&XGPON N2a SFP+ OLT

STANDARDS

- ✧ Complies with SFF-8472
- ✧ Complies with ITU G.987.2
- ✧ Complies with ITU-T G.984.2
- ✧ Complies with FCC 47 CFR Part 15, Class B
- ✧ Complies with FDA 21 CFR 1040.10 and 1040.11

ABSOLUTE MAXIMUM RATING					
Parameter	Symbol	Min.	Max.	Unit	Notes
Storage Ambient Temperature	T _{STG}	-40	85	°C	
Operating Case Temperature	T _c	0	70	°C	
Operating Humidity	OH	5	85	%	
VCC3 Power Supply Voltage	VCC3	0	3.6	V	

RECOMMENDED OPERATING CONDITION						
Parameter	Symbol	Min.	Typ.	Max.	Unit	Notes
Operating Case Temperature	T _c	0		+70	°C	
VCC3 Power Supply Voltage	VCC3	3.13	3.3	3.47	V	
VCC3 Power Supply Current	ICC3		-	750	mA	
Data Rate	XGPON		9.953/2.488		Gbps	
	GPON		2.488/1.244		Gbps	
Power Consumption	P		-	2.5	W	

Shenzhen Opway Communication Co., Ltd.

XGPON TRANSMITTER OPTICAL CHARACTERISTICS						
Parameter	Symbol	Min.	Typ.	Max.	Unit	Notes
Optical Center Wavelength	λ_c	1575		1580	nm	
Optical Spectrum Width (-20dB)	$\Delta\lambda$	-	-	1	nm	
Side Mode Suppression Ratio	SMSR	30			dB	
Optical Waveform Diagram	Compliant with ITU G.987.2					Figure 1
Average Launch Optical Power	AOP	+4		+8	dBm	Launched into SMF @ 0~70°C
Power-OFF Transmitter Optical Power				-39	dBm	Launched into SMF@0~70°C
Extinction Ratio	ER	8.2			dB	PRBS2 ³¹ -1 @9.95Gbps

GPON TRANSMITTER OPTICAL CHARACTERISTICS						
Parameter	Symbol	Min.	Typ.	Max.	Unit	Notes
Optical Center Wavelength	λ_c	1480		1500	nm	
Optical Spectrum Width (-20dB)	$\Delta\lambda$			1	nm	
Side Mode Suppression Ratio	SMSR	30			dB	
Optical Waveform Diagram	ITU-T G.984.2					Figure 2
Average Launch Optical Power	AOP	+3		+7	dBm	Launched into SMF @ 0~70°C
Power-OFF Transmitter Optical Power				-39	dBm	Launched into SMF @ 0~70°C
Extinction Ratio	ER	8.2			dB	PRBS 2 ²³ -1+72CID @2.488Gbps

XGPON TRANSMITTER ELECTRICAL CHARACTERISTICS						
Parameter	Symbol	Min.	Typ.	Max.	Unit	Notes
Data Input Differential Swing		120		850	mV	CML input, AC coupled
Input Differential Impedance		90	100	110	Ω	
Transmitter Enable Voltage - Low		0		0.8	V	
Transmitter Disable Voltage - High		2.0		VCC	V	

GPON TRANSMITTER ELECTRICAL CHARACTERISTICS						
Parameter	Symbol	Min.	Typ.	Max.	Unit	Notes
Data Input Differential Swing		200		1600	mV	LVPECL input, AC coupled
Input Differential Impedance		90	100	110	Ω	
Transmitter Disable Voltage - Low		0		0.8	V	
Transmitter Disable Voltage - High		2.0		VCC	V	
Transmitter Fault Alarm Voltage - Low		0		0.4	V	
Transmitter Fault Alarm Voltage - High		2.4		Vcc	V	

XGPON TRANSMITTER EYE MASK DEFINITIONS AND TEST PROCEDURE

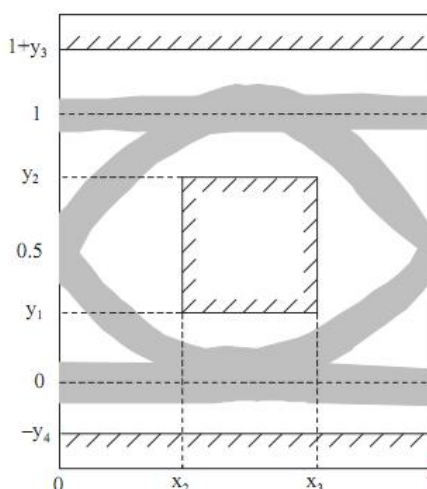

Figure 1 XGPON Transmitter Eye Mask Definitions

X3-X2	Y1	Y2	Y3	Y4	Unit
0.2	0.25	0.75	0.25	0.25	UI

GPON TRANSMITTER EYE MASK DEFINITIONS AND TEST PROCEDURE

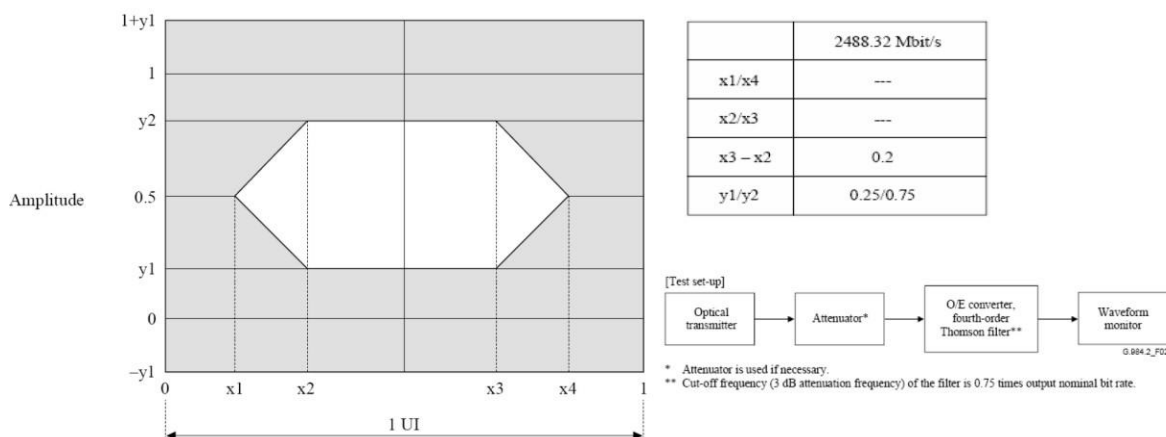

Figure 2 GPON Transmitter Eye Mask Definitions

XGPON RECEIVER OPTICAL CHARACTERISTICS

Parameter	Symbol	Min.	Typ.	Max.	Unit	Notes
Operating Wavelength		1260		1280	nm	
Max Optical input				-3	dBm	input without incurring damage
Sensitivity	SEN			-29.5	dBm	PRBS 2 ²³ -1@2.488Gbps BER ≤1×10 ⁻⁴
Saturation Optical Power	SAT	-9			dBm	PRBS 2 ²³ -1@2.488Gbps BER ≤1×10 ⁻⁴
SD Assert Level				-31	dBm	
SD De-assert Level		-45			dBm	
Hysteresis		0.5		7.5	dB	
Receiver Reflectance				-20	dB	

GPON RECEIVER OPTICAL CHARACTERISTICS						
Parameter	Symbol	Min.	Typ.	Max.	Unit	Notes
Operating Wavelength		1290		1330	nm	
Max Optical input				0	dBm	input without incurring damage
Sensitivity	SEN			-30	dBm	PRBS 2 ²³ -1@1.244Gbps BER ≤1×10 ⁻¹⁰
Saturation Optical Power	SAT	-12			dBm	PRBS 2 ²³ -1@1.244Gbps BER ≤1×10 ⁻¹⁰
SD Assert Level				-32	dBm	
SD De-assert Level		-45			dBm	
Hysteresis		0.5		7.5	dB	
Receiver Reflectance				-20	dB	

RECEIVER ELECTRICAL CHARACTERISTICS						
Parameter	Symbol	Min.	Typ.	Max.	Unit.	Notes
Data Output Differential Swing(XGPON)		340		850	mV	CML output, AC coupled
Data Output Differential Swing(GPON)		400		1600	mV	LVPECL output, AC coupled
Reset width(XGPON)	Trw	25.6			ns	Figure 3
Reset width(GPON)	Trw	12.8			ns	Figure 3
Signal Detect Assert Time	Tsda1			50	ns	Figure 3
Signal Detect Assert Time	Tsda2			50	ns	Figure 3
Signal Detect De-assert Time	Tsdd			12.8	ns	Figure 3
Data recovery time	Trec			50	ns	Figure 3
Reset To ONU Optical Time	Trto	0	-	250	us	Figure 3
Reset Guard Time	Trg	0	-	250	us	Figure 3
Reset-Low		0		0.8	V	
Reset-High		2.0		VCC	V	
Signal Detect Voltage-Low		0		0.4	V	
Signal Detect Voltage-High		2.4		VCC	V	
RSSI Trigger-Low		0		0.8	V	
RSSI Trigger-High		2.0		VCC	V	
Upstream Signal Width	T _{ONT}	1200			ns	Figure 5
RSSI Trigger Delay	T _D	50			ns	Figure 5
RSSI Trigger Width	T _W	600			ns	Figure 5
I ² C Access Prohibited Time	T _P	500			us	

TIMING PARAMETER DEFINITIONS IN BURST MODE SEQUENCE

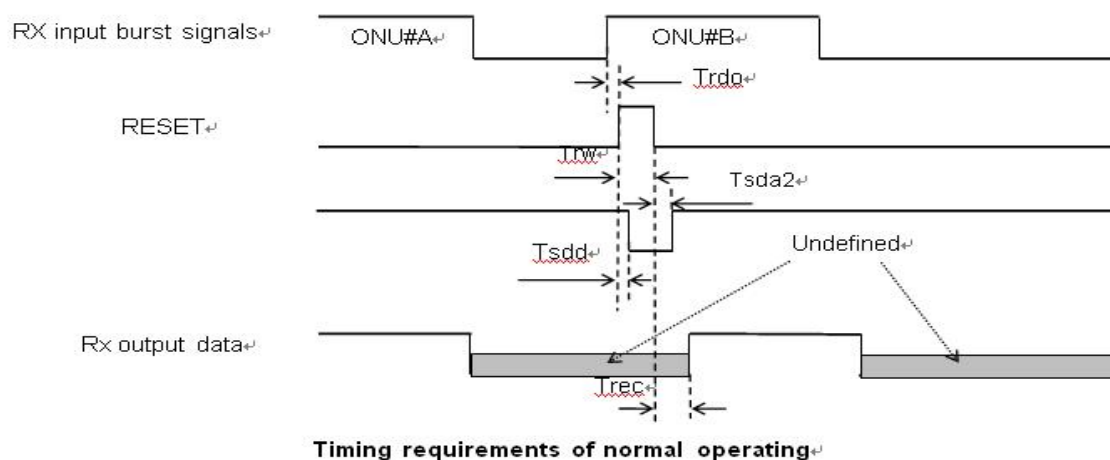
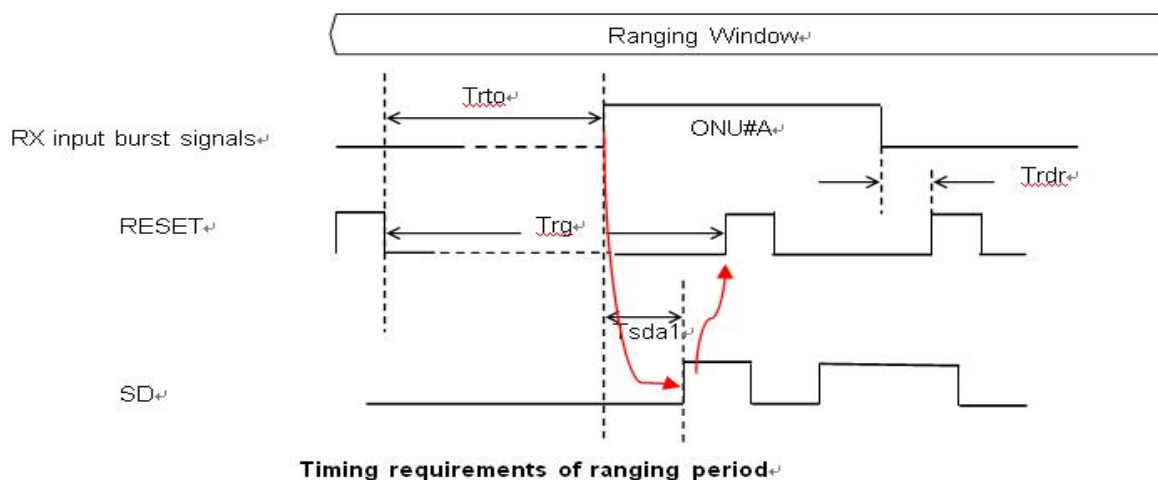
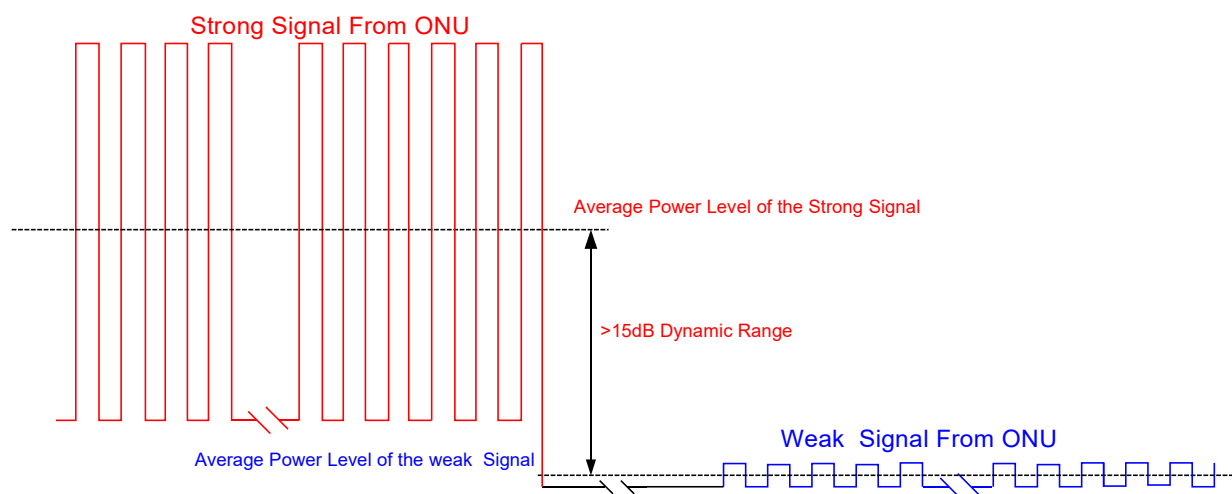

Figure 3 Timing Parameter Definitions in Burst Mode Sequence

BURST MODE RECEIVER DYNAMIC RANGE



TIMING PARAMETER DEFINITIONS IN RSSI TRIGGER

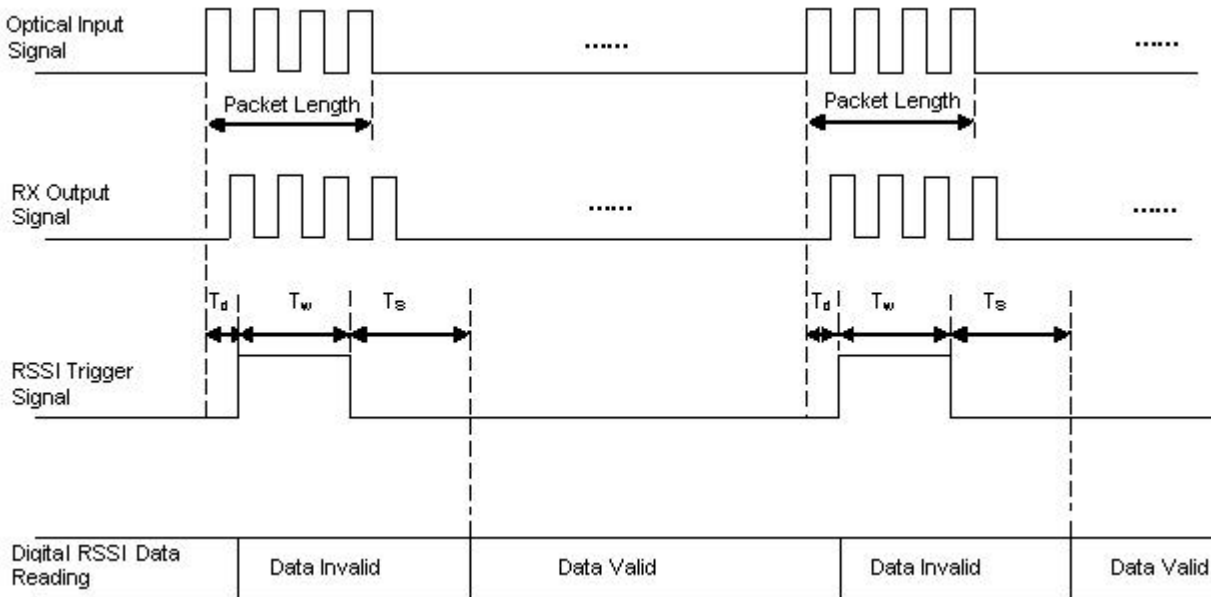

Figure 5 Timing Parameter Definitions in RSSI Trigger

PIN OUT DRAWING

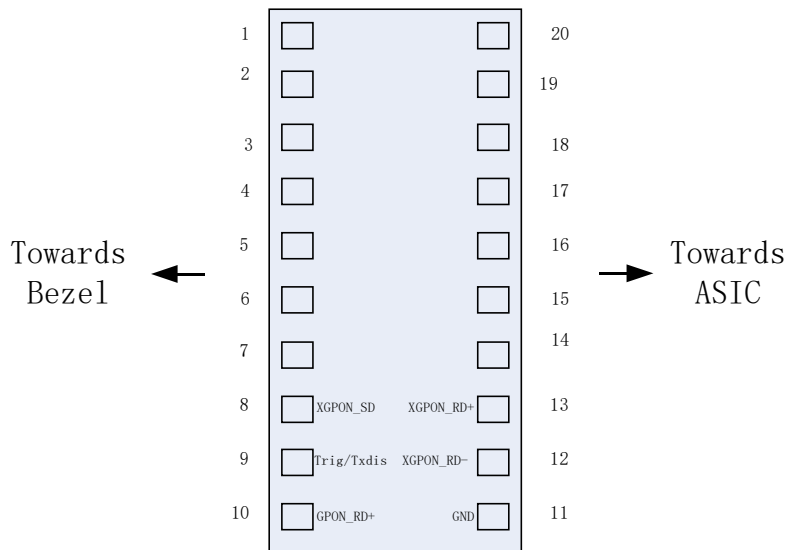

Figure 6 Pin Out Drawing

PIN DESCRIPTION

PIN	Name	Description	Notes
1	GPON_TX+	GPON Non-Inverted Transmit Data in	LVPECL input, AC coupled
2	GPON_TX-	GPON Inverted Transmit Data in	LVPECL input, AC coupled
3	GND	Module Ground	
4	SDA	The data line	The data line of two wire serial interface
5	SCL	The clock line	The clock line of two wire serial interface

6	GPON_RD-	GPON Non-inverted Received Data Out	LVPECL output. DC coupled: No squelch function
7	XGPON_RST	XGPON Burst Receiver Reset	LVTTTL, High level Reset
8	XGPON_SD	XGPON SD Indication	LVTTTL output, active LOW when the receiver lost signal
9	TX_DIS/Trig	Transmitter Disable	LVTTTL Input by 10k pull up resistor, Low: transmitter on
10	GPON_RD+	GPON Non-inverted Received Data Out	LVPECL output, DC coupled; No squelch function
11	GND	Module Ground	
12	XGPON_RD-	XGPON Inverted Received Data Out	CML output, DC coupled; No squelch function
13	XGPON_RD+	XGPON Non-inverted Received Data Out	CML output, DC coupled; No squelch function
14	GPON_SD	GPON SD Indication	LVTTTL output, active LOW when the receiver lost signal
15	VCC3_RX	Receiver 3.3V Power Supply	
16	VCC3_TX	Transmitter 3.3V Power Supply	
17	GPON_RST	GPON Burst Receiver Reset	LVTTTL, High level Reset
18	XGPON_TX+	XGPON Non-Inverted Transmit Data in	CML input, AC coupled
19	XGPON_TX-	XGPON Inverted Transmit Data in	CML input, AC coupled
20	GND	Module Ground	

TYPICAL INTERFACE CIRCUIT

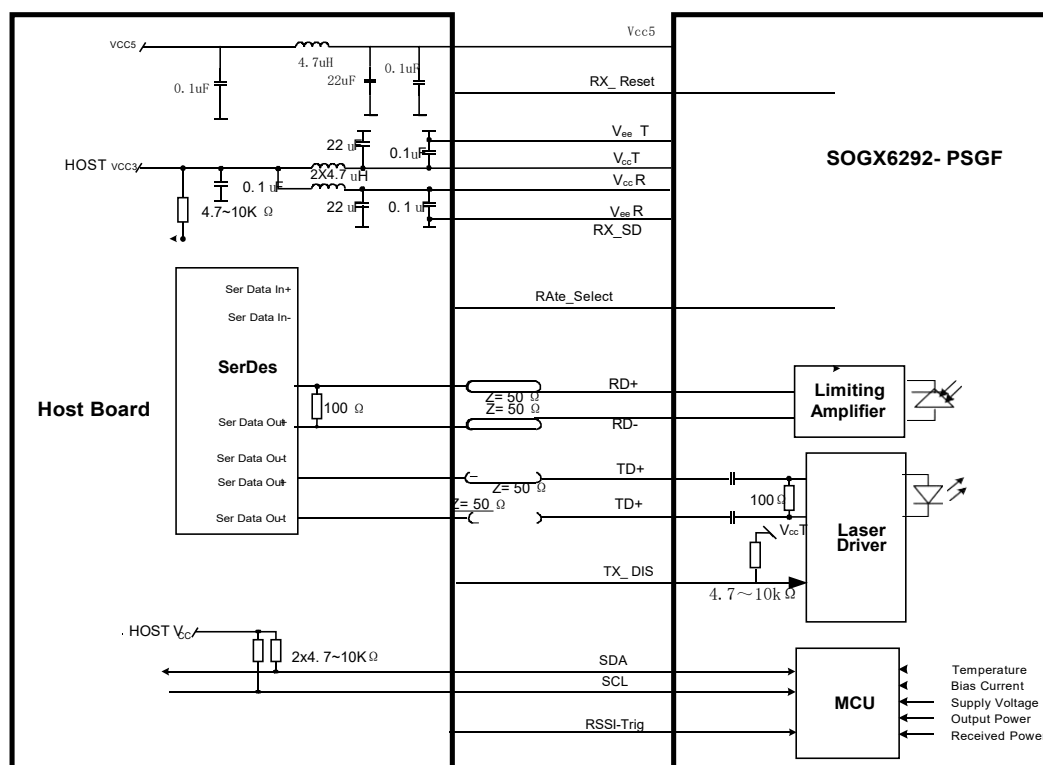

Figure 7 Typical Interface Circuit

PACKAGE OUTLINE

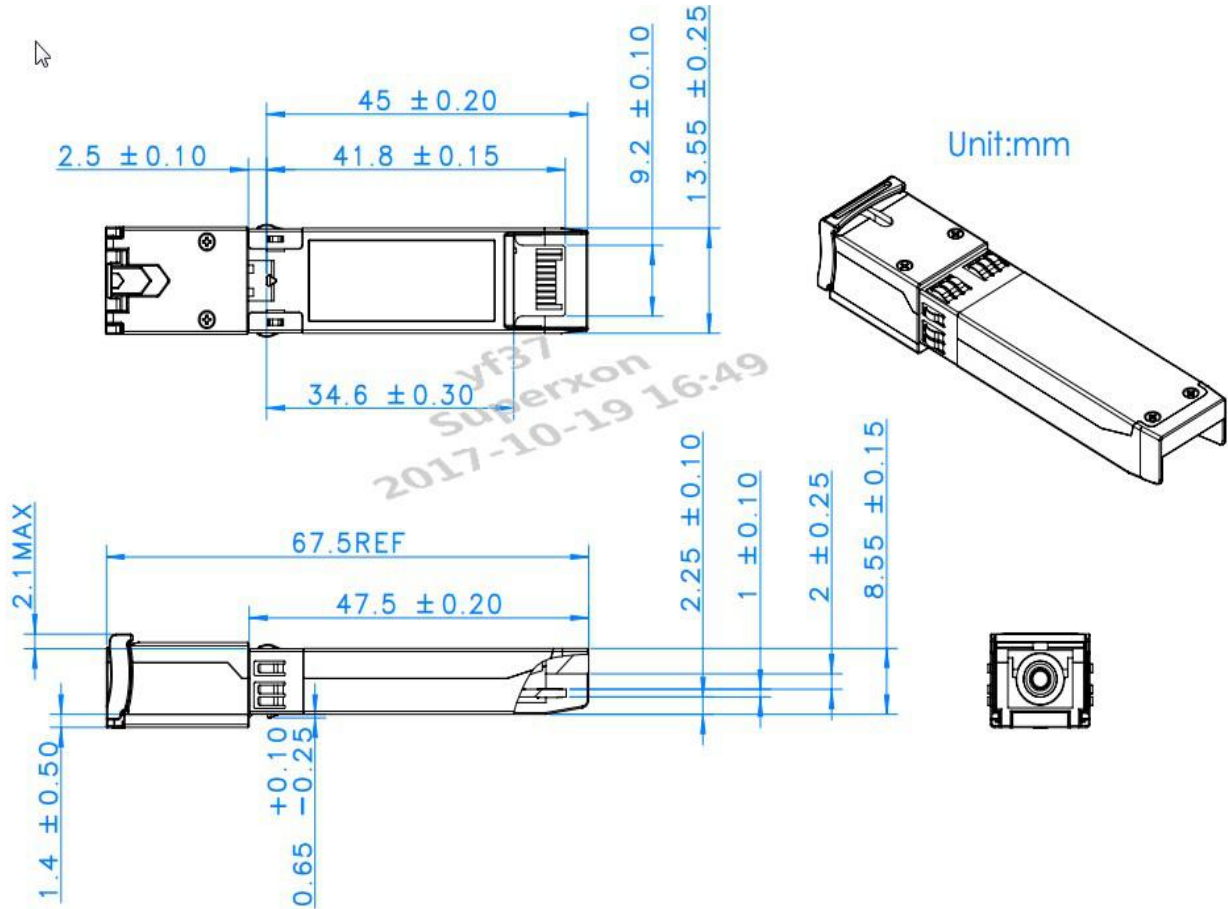

Figure 8 Package Outline

EEPROM INFORMATION

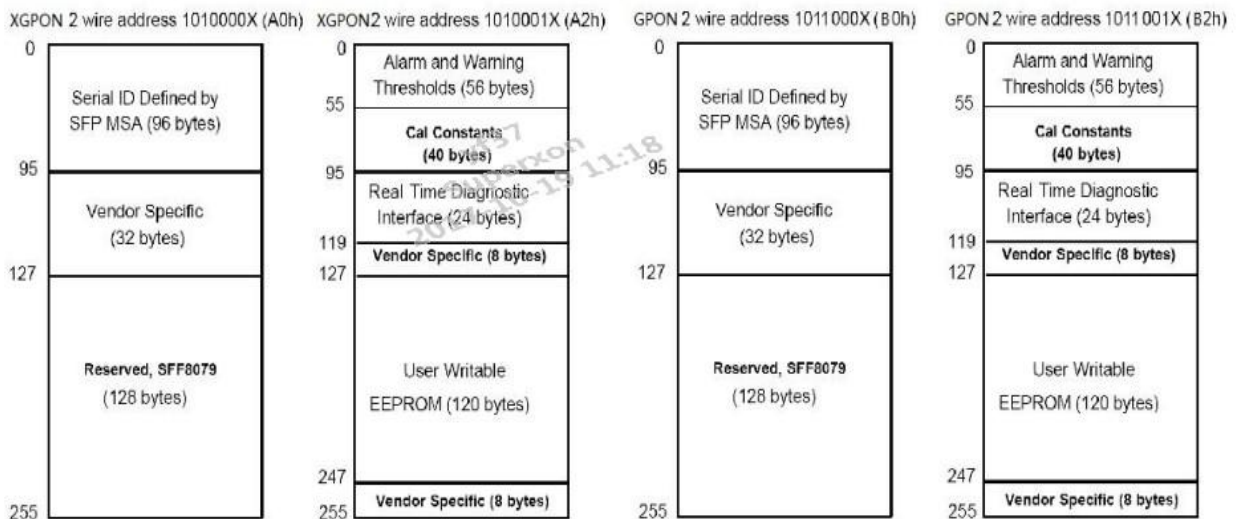

Figure 9 EEPROM Memory Map Specific Data Field Descriptions

DIGITAL DIAGNOSTIC MONITORING INTERFACE				
Parameter	Range	Accuracy	Calibration	NOTES
Temperature	-5 to 75°C	±3°C	Internal	LSB: 1/256C
Voltage	3.0 to 3.6V	±5%	Internal	LSB: 0.1mV
Bias Current	0 to 262mA	±10%	Internal	LSB: 4uA
TX Power	XGPON:2 to 10dBm GPON:1 to 9dBm	±3dB	Internal	LSB: 0.2uW
RX Power	XGPON:-30 to -9dBm GPON:-31 to -12dBm	±3dB	Internal	LSB: 0.1uW

OPWAY reserves the right to make changes to the products or information contained herein without notice. No liability is assumed as a result of their use or application.

No rights under any patent accompany the sale of any such products or information.

Published by Shenzhen OPWAY Communication Co., Ltd.

Copyright © OPWAY

All Rights Reserved